INTRONICS, INC.

MODEL INT-9651

E1 / T1 Multiplexer / Demultiplexer

30 May 1997

Copyright (c) 1997, Intronic, Incorporated
ALL RIGHTS RESERVED

Table of Contents

Paragraph	Topic	Page
1.0	Overview	3
2.0	Functional Description	3
2.1	Multiplexer Operation	3
2.2	Demultiplexer Operation	6
2.3	Headphone / Speaker Operation	7
3.0	Hardware Elements	7
3.1	External Signal Interface	7
3.2	Internal Configuration Options	8
3.3	Preventative Maintenance	8
4.0	Command and Control	9
4.1	Front Panel Operation	9
4.1.1	Logo Menu	11
4.1.2	DMUX Operating Mode Menu	12
4.1.3	DMUX Input Alarms Menu	13
4.1.4	DMUX Output Select Menu	14
4.1.5	DMUX HD Scan Table Menu	16
4.1.6	DMUX Input Source Menu	17
4.1.7	DMUX Clock Output Menu	18
4.1.8	MUX Operating Mode Menu	19
4.1.9	MUX Output Select Menu	20
4.1.10	MUX HD Scan Table Menu	22
4.1.11	MUX Clock Select Menu	23
4.1.12	Headphone Out Select Menu	24
4.1.13	BER Test Loopback Menu	25
4.2	Remote Control	26
4.2.1	On-Line Help Facility	27
4.2.2	Remote Commands	27
5.0	Specifications	33
6.0	Schematic Diagrams	34

1.0 Overview

The INT-9651 is a T1/E1 selectable primary rate Multiplexer and Demultiplexer in a single rack-mountable unit. The Multiplexer and Demultiplexer portions of the unit may be operated independently in either the European E1 mode at 2.048 MBps, or the American T1 mode at 1.544 MBps. Selection of the operating mode is not a factory installed option, but may be made by the user by front panel or remote control commands. This flexibility allows the unit to perform a wide variety of primary rate signals switching functions. Some examples are:

- E1 Multiplex / E1 Demultiplex
- T1 Multiplex / T1 Demultiplex
- E1 Multiplex / T1 Demultiplex
- T1 Multiplex / E1 Demultiplex
- E1 to T1 Conversion
- T1 to E1 Conversion
- 31 Channel Non-Blocking Audio Crosspoint Switch

The multiplexer section of the INT-9651 combines 31 audio inputs into either a single E1 primary rate PCM signal, or a single T1 primary rate signal containing 24 of the 31 audio inputs. The demultiplexer section of the INT-9651 accepts an E1 or T1 signal and extracts 31 or 24 audio signals respectively. The multiplexer includes a full non-blocking crosspoint switch which enables the user to map any audio input signal to one or more E1 or T1 output timeslots. The INT-9651 demultiplexer can also take an E1 or T1 input signal and map any timeslot to any one or more of the audio output BNC's. An internal loopback capability allows the user to internally connect the multiplexer output to the demultiplexer input. In this loopback mode the unit operates as a non-blocking audio crosspoint switch. Both front panel and remote controlled operation are provided. An internal speaker and external headphone jack allow the operator to monitor any multiplexer audio input or demultiplexer E1 or T1 input timeslot.

2.0 Functional Description

A functional block diagram of the INT-9651 and a front and rear panel drawing are shown on the following pages. The upper half of the block diagram describes the multiplexer, and the lower half the demultiplexer.

2.1 Multiplexer Operation

The multiplexer accepts 31 audio (Voice Frequency or VF) inputs via 31 rear panel BNC connectors. These are numbered 1 -15, INSERT, and 17-31. An additional front panel BNC connector labeled INSERT is also available and is directly connected to the rear panel connector of the same name. This has been provided as a convenience to allow the

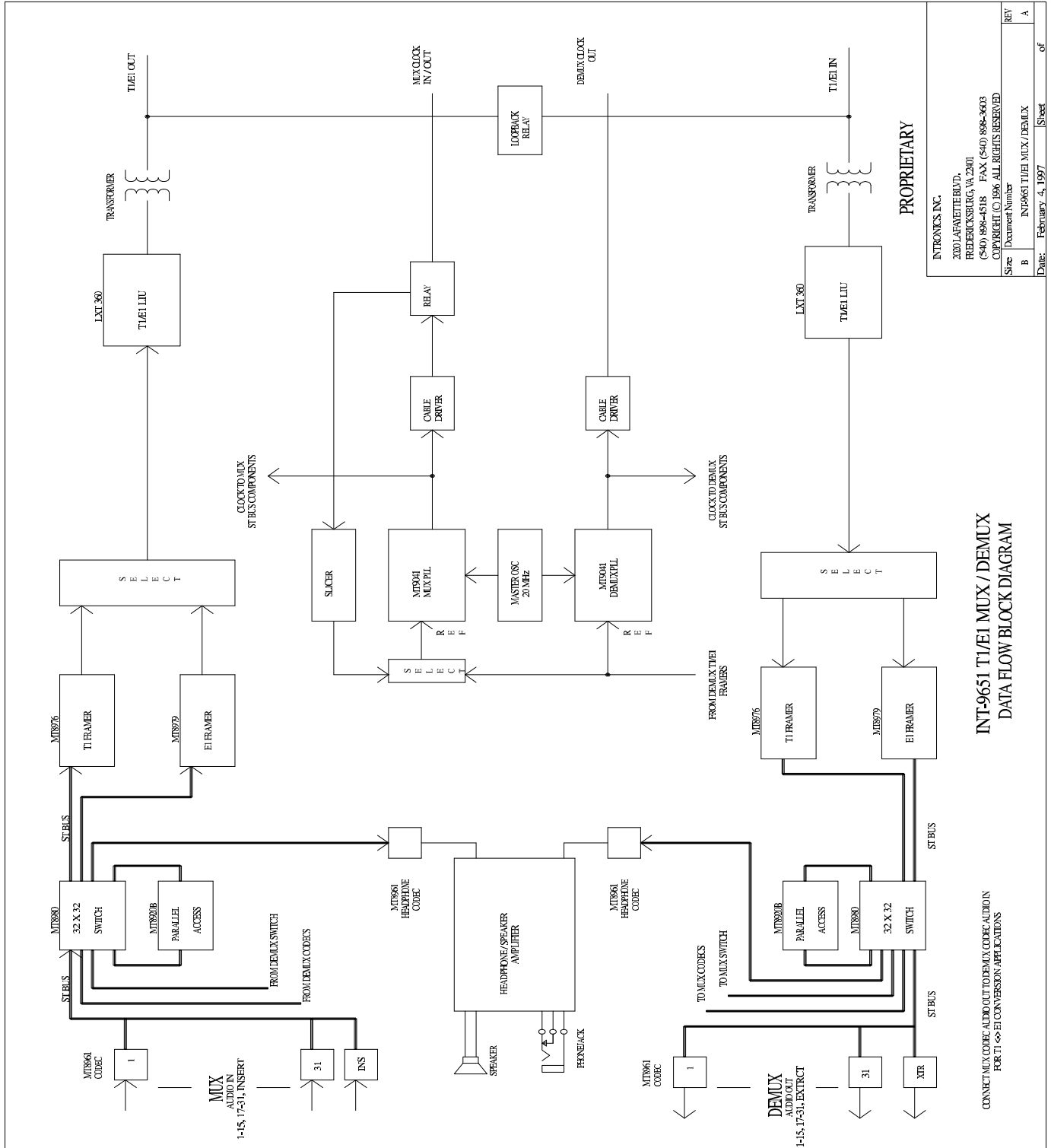

INT-9651 T1/E1 MUX / DEMUX
DATA FLOW BLOCK DIAGRAM

CONNECT MUX CODEC AND/OR OUT TO DEMUX CODEC AND/OR IN
FOR T1 ↔ E1 CONVERSION APPLICATIONS

PROPRIETARY

INTRONICS INC.
2000 LAFFETER BLVD.
FREDERICKSBURG, VA 22001
(540) 894-4516 FAX: (540) 894-3603
COPYRIGHT (C) 1997. ALL RIGHTS RESERVED.
Size Document Number
B INT-9651 T1/E1 MUX / DEMUX
REV A
Date: February 4, 1997 Sheet of

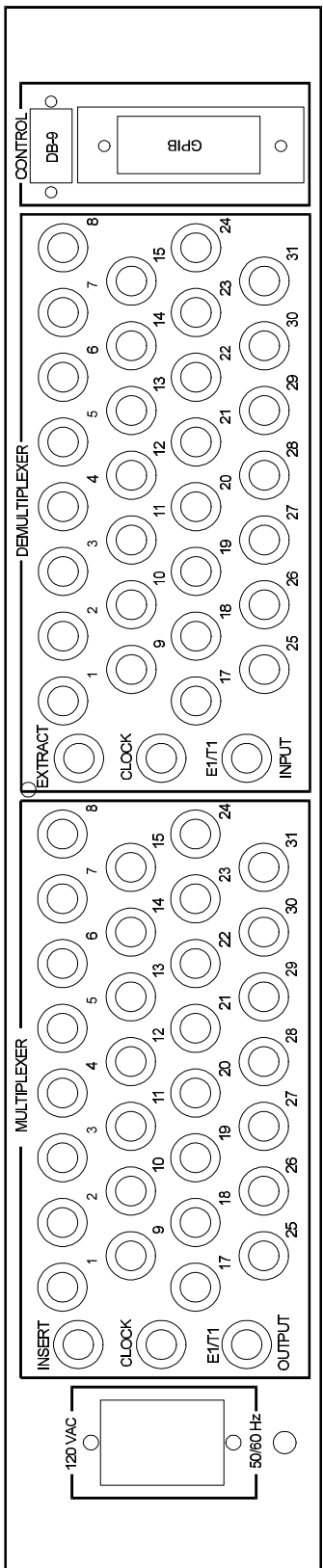
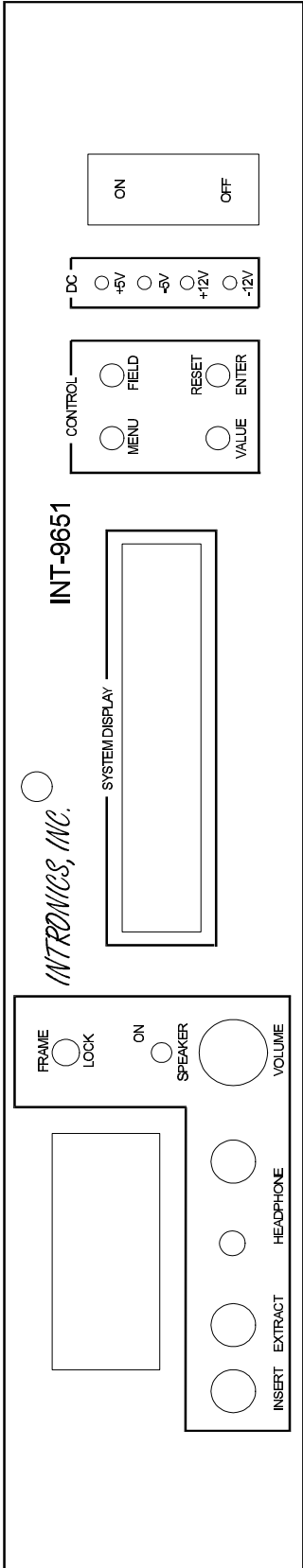

user to input an audio channel from the front of the equipment rack. Each of the 31 VF audio inputs are applied to a CODEC circuit which converts the analog audio input to digital PCM samples. Specifically the PCM samples are 8 bit A-Law companded format at 8000 samples per second. If the multiplexer operating mode is T1, then these samples are sent to the Parallel Access circuit where they are converted from A-Law to U-Law or Twos Complement as selected by the operator. The samples are then sent to a 32 x 32 switching circuit via an internal Serial Telecommunications Bus (ST Bus). The switching circuit allows the samples from any of the 31 VF inputs to be placed into any one or more timeslots of a T1 or E1 PCM output stream. The T1 PCM format has 24 timeslots (1 - 24) available for sampled VF audio. The E1 format has 31 timeslots (1 - 31) available for this purpose. Often E1 timeslot 16 is reserved for signaling information rather than sampled VF audio. The INT-9651 however allows sampled VF audio to be placed into E1 timeslot 16. The switching circuit output is sent to a T1 framer circuit and an E1 framer circuit. The framer circuits add synchronization data to the PCM stream. For the T1 multiplexer operating mode the user may select D3/D4, ESF or SLC96 framing. For E1 operating mode the user may select CEPT (ITU) framing only. The framer circuit also adds zero suppression coding (ZCS) to the PCM stream. This coding is normally used to avoid long sequences of zeros that would complicate the job of clock recovery by the unit receiving the PCM stream. For T1 operating mode B8ZS, B7HI and NONE zero code suppression may be selected. For E1 HDB3 and NONE may be selected. The output of the T1 and E1 framers is sent to a selector. For the T1 operating mode the T1 framer output is sent to the Line Interface Unit (LIU). For E1 mode the E1 framer output is sent to the LIU. The LIU converts the selected framer's output to a series of bipolar alternating mark pulses conforming to the required T1 or E1 line specifications. This is output via a rear panel E1/T1 Output Twinax connector.

The multiplexer requires a clock source to be used to generate the timing signals necessary to perform VF sampling and PCM stream framing. An Internal clock, External clock, or Demux Recovered clock may be selected by the operator. The rear panel Clock BNC connector may be used to output the internal clock to an external device, or to input an external clock from an external device. Using the Demux Recovered clock synchronizes the multiplexer clock source to the PCM stream input to the demultiplexer.

2.2 Demultiplexer Operation

The demultiplexer is the mirror image of the multiplexer. It accepts a T1 or E1 input via a rear panel E1/T1 Input Twinax connector. This is processed by the LIU to extract the PCM stream and perform bit clock recovery. The LIU output is sent to the T1 framer when the demultiplexer is in T1 mode, or to the E1 framer in E1 mode. The framer removes the zero suppression coding selected by the operator, and synchronizes to the PCM framing information. When frame synchronization has been obtained the green Frame Lock LED display on the front panel is turned on. The framer output is sent to a 32 x 32 switching circuit that allows any input timeslot to be output to any one or more of the 31 VF audio outputs. If the demultiplexer operating mode is T1 then the switching circuit outputs are sent to the Parallel Access circuit where the user selected U-Law or

Twos Complement input samples are converted to A-Law. The samples are sent to 31 A-Law Codecs which convert the samples to analog audio. The Codec outputs are sent to cable driver buffer circuits and are output via the VF Out audio (1-15, XTR, 17-31) BNC connectors. The front panel EXTRACT BNC connector is directly connected to the rear panel EXTRACT connector. This has been provided as a convenience to allow the user to output an audio channel from the front of the equipment rack.

The clock source for demultiplexer operation is always the T1 or E1 PCM input stream itself. The recovered clock is output via the rear panel Clock BNC connector.

2.3 Headphone / Speaker Operation

The operator may monitor any of the multiplexer VF audio inputs, any demultiplexer input timeslot, INSERT or the EXTRACT using the headphone / speaker circuitry. A mini-jack stereo headphone connector and BNC connector are provided on the front panel for headphone audio output. A volume knob controls the headphone signal amplitude. An internal 7 Watt amplifier and speaker are also provided. An on/off switch controls the speaker operation. Speaker loudness is controlled by the same volume knob as the headphone output.

3.0 Hardware Elements

The INT-9651 is comprised of a single 12" x 12" multi-layer printed circuit card enclosed in a 3 1/2" high rack mounted chassis. The front panel assembly includes a VFD display, four momentary contact switches, four DC power status indicator LED's, a Frame Lock LED, a headphone jack, a speaker and a BNC monitor jack with gain control, INSERT and EXTRACT BNC's for the Multiplexer and Demultiplexer sections respectively, and the A/C power switch. The command and control section below describes front panel operation. The rear panel includes four functional areas: A/C power, Multiplexer Inputs, Demultiplexer Outputs, and Remote Control.

3.1 External Signal Interface

All signal interfaces to the INT- 9651 are accommodated via rear panel connectors with the exception of the headphone jack and the variable output headphone BNC. The INSERT BNC is found on both the front and rear of the unit, and is the same signal connected to both front mounted and rear mounted connectors. The same is true for the EXTRACT BNC. The E1/T1 input and output are found on TWINAX connectors on the center conductor, and the middle conductor. The TWINAX connectors have the shield connected to chassis ground.

3.2 *Internal Configuration Options*

The INT-9651 printed circuit board provides for several jumper selectable options as described below:

Installation of jumpers J1, JP9, JP15 and JP19 on the printed circuit enable in-circuit programming of U16, U32 and U76. As delivered from the factory these jumpers are not installed.

Installation of jumpers on pins 3-4 and 7-8 on JP1 is used for the RS232-A and are factory installed. This configuration disables hardware handshaking. To enable hardware handshaking, install jumpers on pins 1-2 and 5-6. JP2 has no jumpers installed. JP2 controls hardware handshaking for RS-232B. This port is unused at the present time.

Jumpers JP14 and JP18 are not installed at the factory. They are used to select unbalanced 75 Ohm E1 operation via the onboard SMA connectors. Chassis modifications are also required to support this operational mode.

3.3 *Preventive Maintenance*

The air intake filter is accessible from the front panel and may be removed and washed in warm water to clean. There are no other routine maintenance procedures. No periodic alignments or adjustments are required.

4.0 *Command and Control*

The INT-9651 may be configured by the user through a front panel display and control switch assembly, or through the use of its RS-232 or IEEE-488 remote control interfaces. Commands may be accepted at any time from any of these sources and are processed on a first come first served basis. The configuration of the unit is stored in battery backed up memory at all times. It is preserved while the unit is powered down, or during a power failure, and is restored when power is applied. The front panel RESET switch performs the same function as powering the unit off and back on.

4.1 *Front Panel Operation*

A Vacuum Fluorescent Display (VFD) 2 lines by 20 characters each and four up/down toggle switches provide the front panel controls. The four switches are labeled "MENU, FIELD, VALUE, and ENTER".

The MENU switch is associated with the top line of the display and selects the primary command. There are thirteen primary commands that are selected by the MENU switch and displayed on the top line of the display:

MENU SELECTIONS
Intronics, Inc.
DMUX Operating Mode
DMUX Input Alarms
DMUX Output Select
DMUX HD Scan Table
DMUX Input Source
DMUX Clock Output
MUX Operating Mode
MUX Output Select
MUX HD Scan Table
MUX Clock Select
Headphone Out Select
BER Test Loopback

To select one of the above the MENU switch is used. When pressed down once the selection displayed advances down the list one item, and wraps around from bottom back to the top at the end of the list. When pressed up the selection displayed moves up one item, and wraps from top down to the bottom. If the MENU switch is held up or down the selection displayed continues to move through the list until the switch is released. By using the MENU and FIELD switches the operator may examine the current configuration of the unit without changing that configuration.

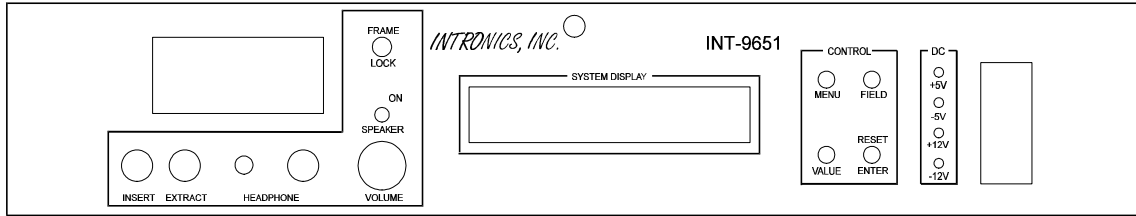

For each MENU command there are several FIELDS that may be selected. For example the DMUX Output Select MENU command is used to select the mapping associated between the output VF audio BNC's and various PCM input stream timeslots for the demultiplexer. The FIELD switch is used to select one of the 31 output BNC's or the headphones, or ALL of the BNC's, and map it to a timeslot. For each FIELD, the VALUE switch is used to select a data item. In this example the VALUE switch selects E1 timeslot 15 for the VF audio output number 6. This is displayed as shown below:

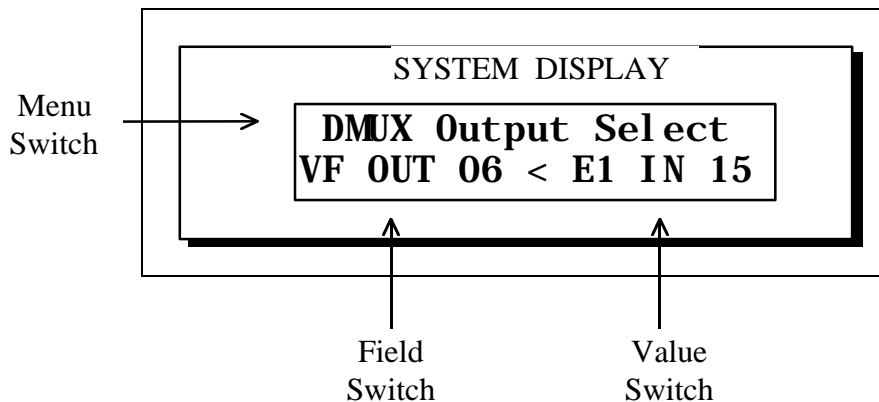

This is a hierarchical selection structure. MENUS have FIELDS, and FIELDS have VALUES. When the user presses the MENU and FIELD switches the unit responds by displaying the current setting of that selected data item. The VALUE switch may then be used to modify the setting for the selected data item. When the user has completed selection of the desired MENU, FIELD, and VALUE then the **ENTER switch must be pressed to cause the new setting to be accepted.**

The ENTER switch must be pressed to cause any new selections to take effect!! The MENU, FIELD and VALUE switches do NOT cause any changes to be made to the unit's operational setup until the ENTER switch is pressed!!

4.1.1 Logo MENU

The "Intronics. Inc." MENU selection is used for identification purposes only, and is referred to as the logo menu. There are 3 FIELDS associated with this MENU selection, and no VALUE selections:

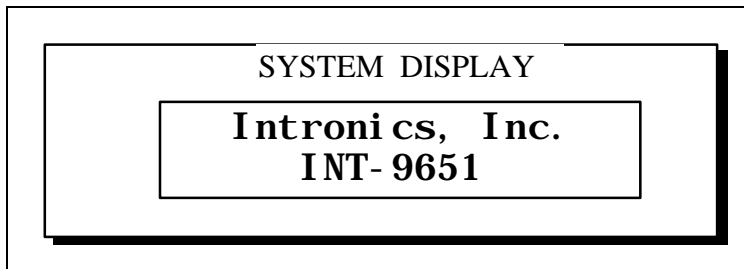
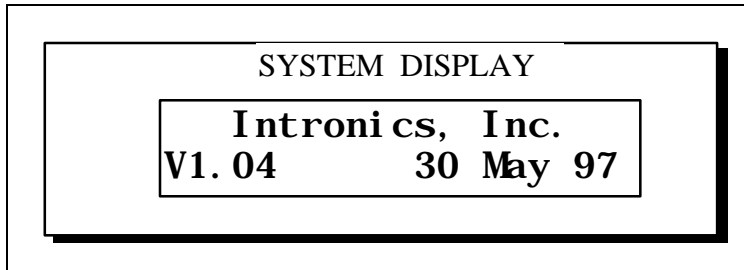
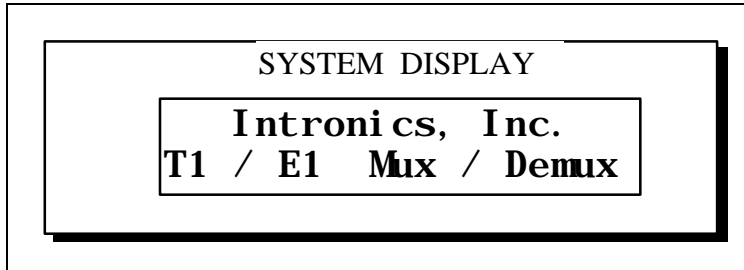

4.1.2 DMUX Operating Mode MENU

This menu selects the primary operating mode for the demultiplexer. There are three FIELDS associated with this MENU selection. These are the framing mode, the zero code suppression (ZCS) mode and the sample companding mode. For example:

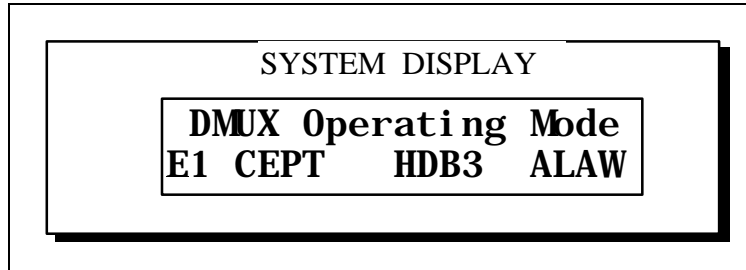

The FIELD switch is used to select one of the three operating modes on the second line of the display. The display indicates the FIELD selected by underlining its first letter. The VALUE switch is then used to modify the selected field.

The framing mode FIELD may be set to E1 CEPT, T1 D3/D4, T1 ESF or T1 SLC96.

When the framing mode is E1 CEPT, the ZCS FIELD may be set to either HDB3 or NONE. The sample companding FIELD may be set to ALAW only.

When the framing mode is any of the T1 selections, the ZCS FIELD may be set to B8ZS, B7HI or NONE. The sample companding FIELD may be set to ULAW or 2CPL (twos complement).

REMEMBER :

The ENTER switch must be pressed to cause any new selections to take effect!! The MENU, FIELD and VALUE switches do NOT cause any changes to be made to the unit's operational setup until the ENTER switch is pressed!!

4.1.3 DMUX Input Alarms Menu

The DMUX Input Alarms menu is used to display the status of the demultiplexer input alarms. There are no FIELD or VALUE selections.

When the demultiplexer is operating in E1 mode two alarms are displayed in this MENU: the Frame Sync Alarm (FSYNC) and the AIS Alarm. When the INT-9651 is operating correctly, both of these alarms will be displayed as "OK". When frame synchronization is lost the FSYNC alarm will indicate "ERR". This is the same as the Frame Lock LED indication on the front panel being off. The AIS alarm is flagged as "ERR" when all ones are present in the E1 input stream.

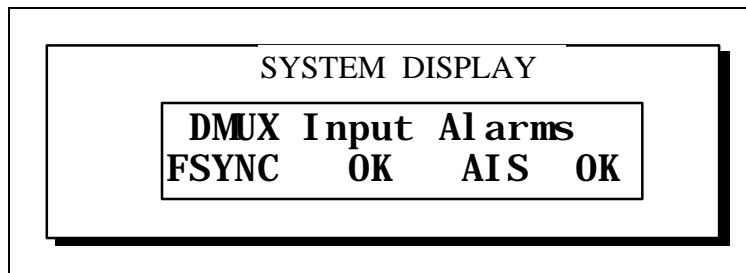

When operating in T1 mode two alarms are displayed in this menu: the Frame Sync Alarm (FSYNC) and the YALR Alarm. When the INT-9651 is operating correctly, both of these alarms will be displayed as "OK". When frame synchronization is lost the FSYNC alarm will indicate "ERR". This is the same as the Frame Lock LED indication on the front panel being off. The YALR (yellow) alarm is flagged as "ERR" when the framer is receiving a zero in bit position two of all 24 T1 input timeslots.

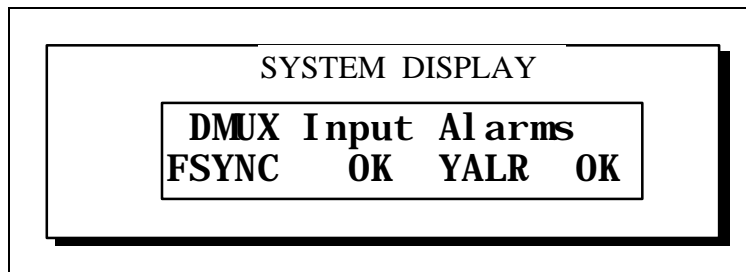

4.1.4 DMUX Output Select Menu

The DMUX Output Select menu is used to map T1 or E1 PCM input timeslots to the audio VF Out BNC's, the headphone, or the extract channel. The FIELD switch selects the output and the VALUE switch selects the input timeslot to map to that output.

The FIELD switch selects the audio outputs "HEADPHONE", "VF OUT 01 through 15", "EXTRACT", "VF OUT 17 through 31", or "VF OUT ALL".

The VALUE switch selects the input time slots "E1 IN 01 through E1 IN 31" or "T1 IN 01 through T1 IN 24", and "DEFAULT". Also when the FIELD selected is HEADPHONE, the VALUE switch allows the selection "*SCAN*" as well.

In the example below E1 input time slot 12 is mapped to the demultiplexer VF audio output BNC 03:

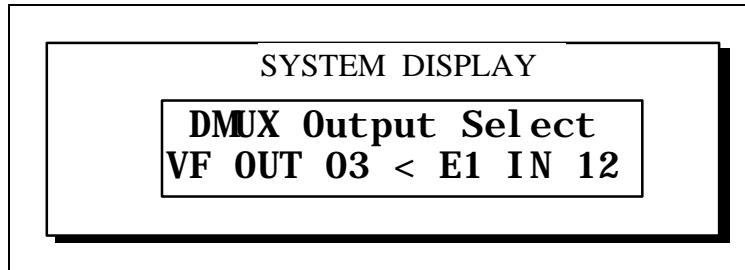

In E1 mode the example below maps E1 IN timeslots 1 through 15 and 17 through 31 to VF Out BNC connectors 1 through 15 and 17 through 31 respectively. E1 IN 16 is mapped to EXTRACT. In T1 mode the example below maps T1 IN timeslots 1 through 15 and 17 through 24 to VF Out BNC connectors 1 through 15 and 17 through 24 respectively. T1 IN 16 is mapped to EXTRACT. T1 IN timeslot 1 is also mapped to VF Out BNC's 25 through 31. HEADPHONE is mapped to timeslot 1 for both T1 and E1.

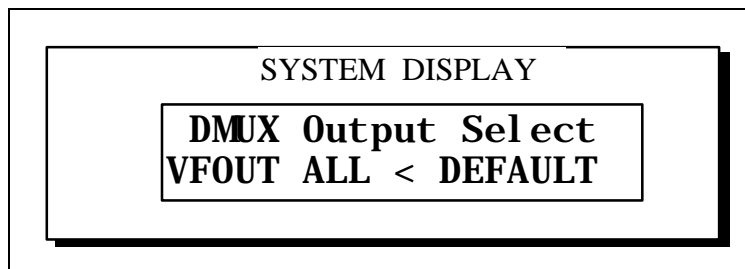

In the example below the demultiplexer HEADPHONE output is selected to be a SCAN of the input timeslots, with dwell times as specified in the demultiplexer headphone SCAN table.

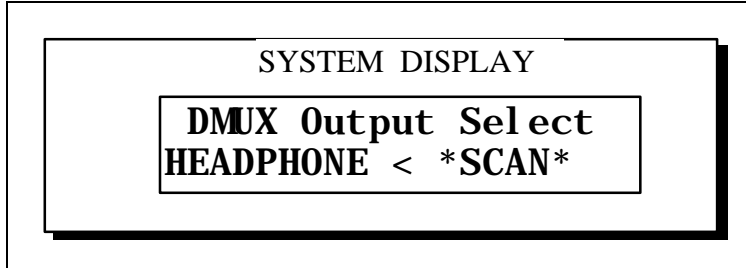

When ENTER is pressed the SCAN begins and the display shows each input timeslot number as it is mapped to the demultiplexer HEADPHONE output. To stop the SCAN at the timeslot currently mapped to the HEADPHONE simply press ENTER again.

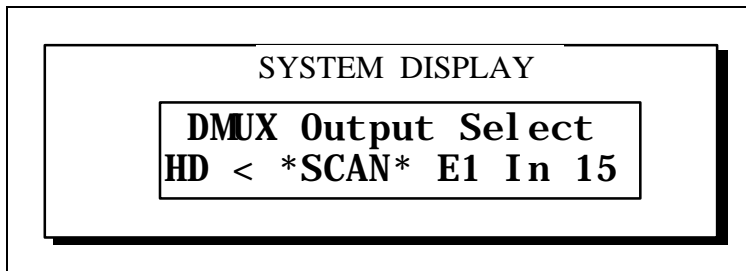

4.1.5 DMUX HD Scan Table MENU

The DMUX HD SCAN Table MENU is used to enable and disable input timeslots to be scanned for the demultiplexer HEADPHONE output. The FIELD switch selects the timeslot to enable or disable, and the VALUE switch selects either "OFF" to disable scanning or a time between 1 and 99 seconds to wait before moving to the next enabled channel in the SCAN table (dwell time). Note that headphone scanning must be enabled in the DMUX OUTPUT SELECT menu for scanning to be operational.

In the example below T1 input timeslot 04 is enabled in the SCAN table with a dwell time of 2 seconds.

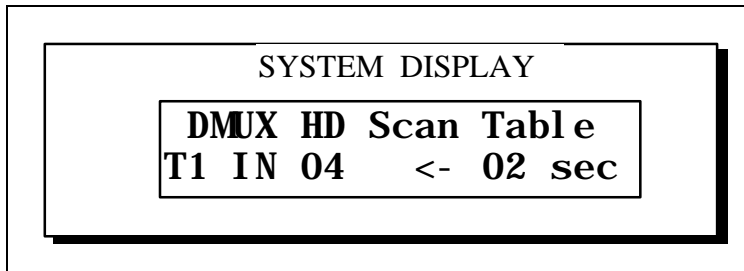

All input timeslots are turned off in the example below:

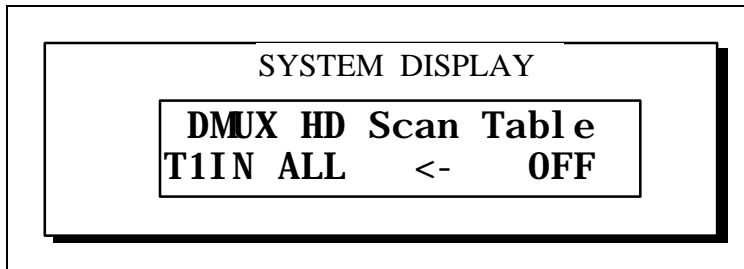

All input timeslots are turned on with a dwell time of 3 seconds in the example below:

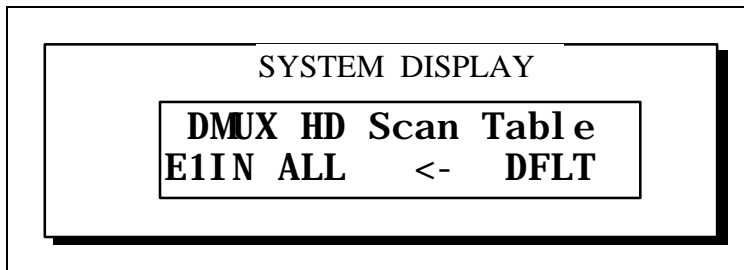

4.1.6 *DMUX Input Source MENU*

Selects the T1 or E1 input signal source to the demultiplexer.

The following example selects the rear panel demultiplexer E1/T1 TWINAX input connector as the demultiplexer input signal source:

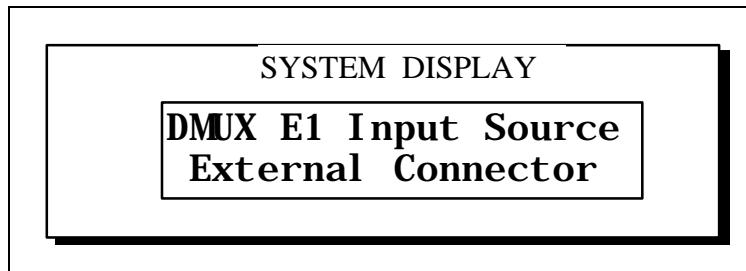

The example below selects the multiplexer output as the demultiplexer input signal source. This is a loopback function. The multiplexer and demultiplexer must be set up in the same operating mode (e.g. framing, zero code suppression and sample companding) or the demultiplexer will fail to correctly process the multiplexer output. Similarly, the multiplexer clock selection **MUST** be DMUX RECOVERED.

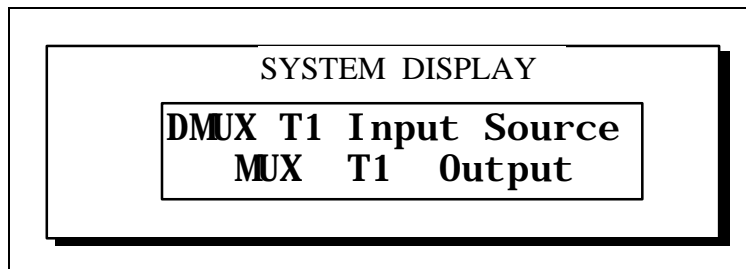

4.1.7 DMUX Clock Output

Selects the clock to be output on the demultiplexer clock BNC connector. The clock is recovered from the T1 or E1 input. Either the bit clock or the frame clock may be selected.

The example below selects the bit clock when the demultiplexer is operating in E1 mode:

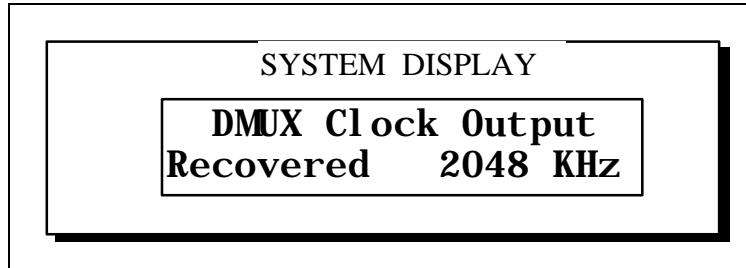

The example below selects the bit clock when the demultiplexer is operating in T1 mode:

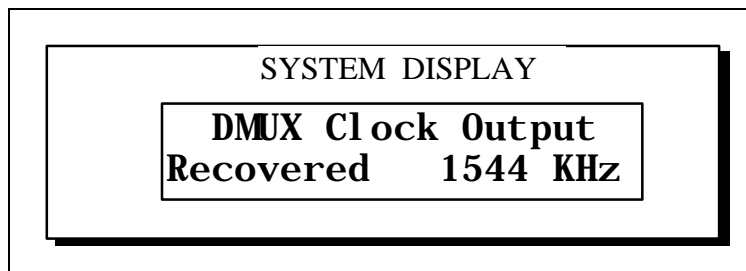

The example below selects the frame clock when the demultiplexer is operating either T1 or E1 modes:

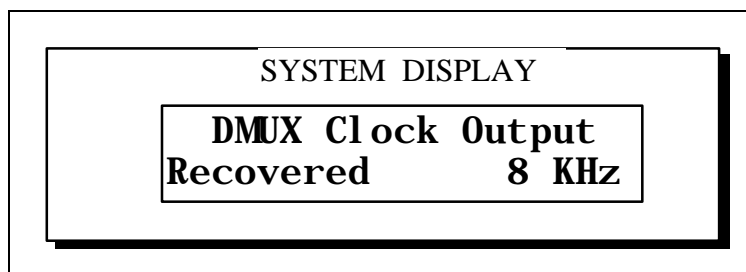

4.1.8 MUX Operating Mode MENU

This menu selects the primary operating mode for the multiplexer. There are three FIELDS associated with this MENU selection. These are the framing mode, the zero code suppression (ZCS) mode and the sample companding mode. For example:

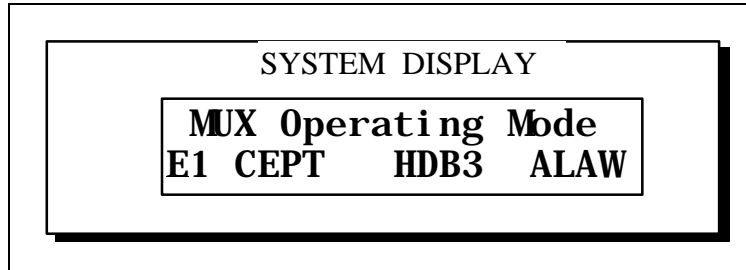

The FIELD switch is used to select one of the three operating modes on the second line of the display. The display indicates the FIELD selected by underlining its first letter. The VALUE switch is then used to modify the selected field.

The framing mode FIELD may be set to E1 CEPT, T1 D3/D4, T1 ESF or T1 SLC96.

When the framing mode is E1 CEPT, the ZCS FIELD may be set to either HDB3 or NONE. The sample companding FIELD may be set to ALAW only.

When the framing mode is any of the T1 selections, the ZCS FIELD may be set to B8ZS, B7HI or NONE. The sample companding FIELD may be set to ULAW or 2CPL (twos complement).

4.1.9 MUX Output Select Menu

The MUX Output Select menu is used to map audio VF IN BNC's or the INSERT input to T1 or E1 output timeslots or the multiplexer headphone output. The FIELD switch selects the output timeslot and the VALUE switch selects the audio VF input source.

The FIELD switch selects "HEADPHONE", "E1 OUT 01 through 31" or "T1 OUT 01 through 24", "E1 ALL" or "T1 ALL".

The VALUE switch selects "VF IN 01 through 15", "INSERT", "VF IN 17 through 31" and "DEFAULT". Also when the FIELD selected is HEADPHONE, the VALUE switch allows the selection "*SCAN*" as well.

In the example below VF audio input BNC 03 is mapped to the E1 output timeslot 12:

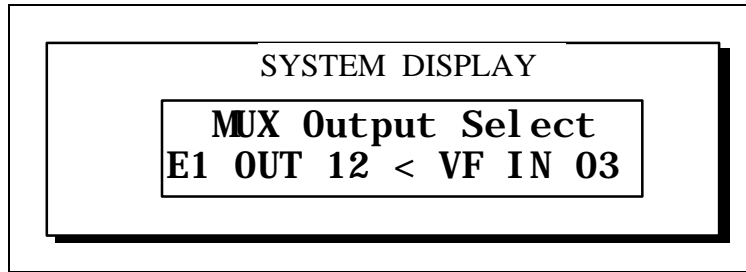

In E1 mode the example below maps VF audio input BNC's 1 through 15 and 17 through 31 to E1 output timeslots 1 through 15 and 17 through 31 respectively. INSERT is mapped to E1 output timeslot 16. In T1 mode the example below maps VF audio input BNC's 1 through 15 and 17 through 24 to T1 output timeslots 1 through 15 and 17 through 24 respectively. INSERT is mapped to T1 output timeslot 16. VF audio input 1 is also mapped to HEADPHONE for both T1 and E1.

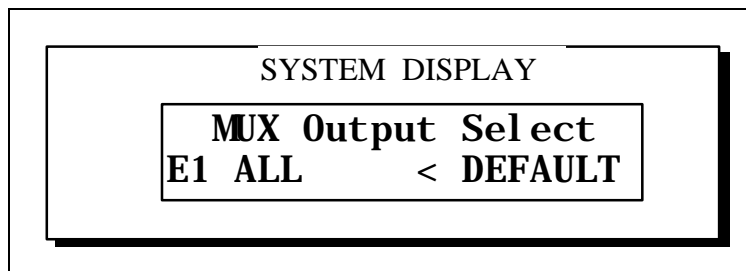

In the example below the multiplexer HEADPHONE output is selected to be a SCAN of the VF audio input BNC's and INSERT, with dwell times as specified in the multiplexer headphone SCAN table.

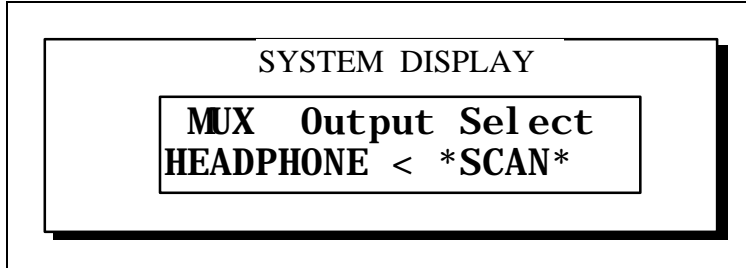

When ENTER is pressed the SCAN begins and the display shows each input BNC number or INSERT as it is mapped to the multiplexer HEADPHONE output. To stop the SCAN at the input currently mapped to the HEADPHONE simply press ENTER again.

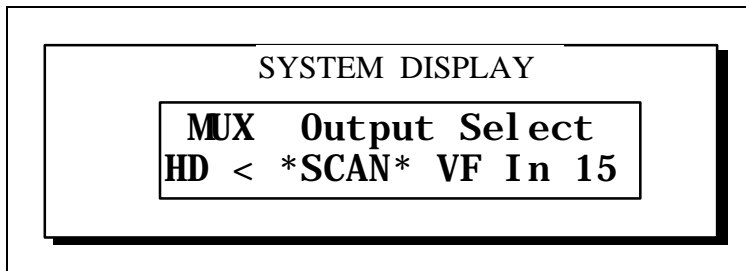

4.1.10 MUX HD Scan Table MENU

The MUX HD SCAN Table MENU is used to enable and disable audio VF inputs or INSERT to be scanned for the multiplexer HEADPHONE output. The FIELD switch selects the input to enable or disable, and the VALUE switch selects either "OFF" to disable scanning or a time between 1 and 99 seconds to wait before moving to the next enabled channel in the SCAN table (dwell time). Note that headphone scanning must be enabled in the MUX OUTPUT SELECT menu for scanning to be operational.

In the example below audio VF input BNC 04 is enabled in the SCAN table with a dwell time of 2 seconds.

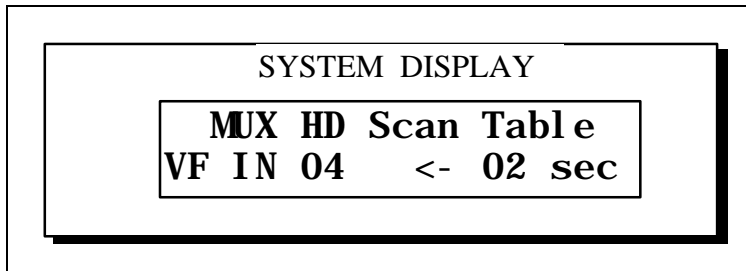

All audio VF input BNC's and INSERT are turned off in the example below:

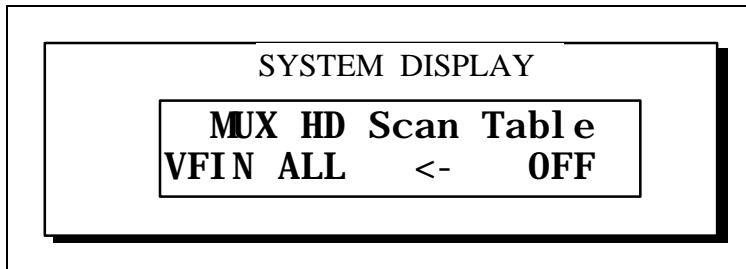

All audio VF input BNC's and INSERT are turned on with a dwell time of 3 seconds in the example below:

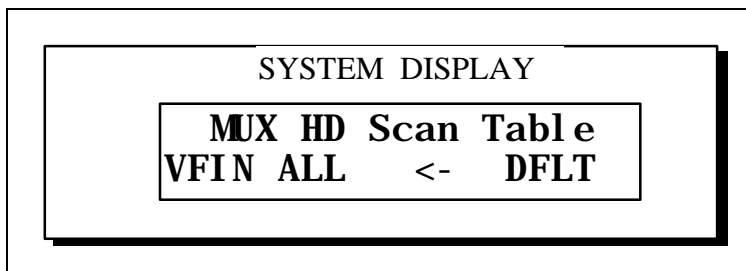

4.1.11 MUX Clock Select Menu

The MUX CLOCK SELECT menu is used to select the clocking source for the multiplexer. The options selected by the FIELD switch are:

E1 Multiplexer Operating Mode	T1 Multiplexer Operating Mode
Internal, Out = 2048 KHz	Internal, Out = 1544 KHz
Internal, Out = 8 KHz	Internal, Out = 8 KHz
External, In = 8 KHz	External, In = 8 KHz
External, In = 2048 KHz	External, In = 1544 KHz
DMUX Recovered	DMUX Recovered

Internal selects the clock built into the INT-9651 for use by the multiplexer. The multiplexer CLOCK BNC connector outputs this clock at either the PCM bit rate (2048 KHz E1 or 1544 KHz T1), or at the frame rate of 8 KHz as selected by the operator.

External selects a clock input into the INT-9651 via the multiplexer CLOCK BNC connector. It is quite often desirable to synchronize (phase lock) the multiplexer clock to an external source. This mode of operation provides that capability. The input clock may be either at the PCM bit rate or at the 8 KHz frame rate as selected by the operator. If no external input clock is present the multiplexer will continue to operate by using its internal clock, even if external clock input has been selected by the operator.

DMUX Recovered selects the clock recovered from the demultiplexer T1 or E1 PCM input for use by the multiplexer. This is similar to external clock operation, and the multiplexer clock is phase locked to the demultiplexer PCM input frame clock. Since the frame clock for E1 and T1 are identical (8 KHz) it is not necessary for the demultiplexer and multiplexer to be operating in the same framing mode when DMUX Recovered is selected. **Note** that when the DMUX Input Source MENU is selected to be MUX Output (loopback), DMUX Recovered **MUST BE** selected to be the multiplexer clock.

A sample display is shown below:

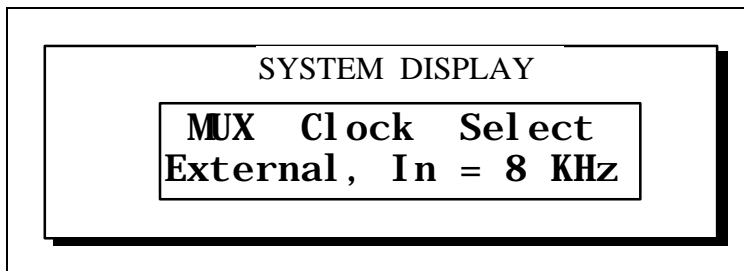

4.1.12 Headphone Out Select MENU

This menu selects the audio source for the headphones and internal speaker. The options selected by the FIELD switch are:

Headphone Output Selections
MUX HD Audio
DMUX HD Audio
MUX Insert Audio
DMUX Extract Audio
OFF

MUX HD audio selects the multiplexer headphone audio output as specified by the HEADPHONE FIELD of the MUX Output Select MENU. The audio sources available using that MENU are VF IN 01 through VF IN 31, INSERT and SCAN.

DMUX HD audio selects the demultiplexer headphone audio output as specified by the HEADPHONE FIELD of the DMUX Output Select MENU. The audio sources available using that MENU are E1 IN 01 through 31 or T1 IN 01 through 24, and SCAN.

MUX Insert Audio selects the INSERT BNC audio input.

DMUX Extract Audio selects the EXTRACT BNC audio output.

A sample display is shown below:

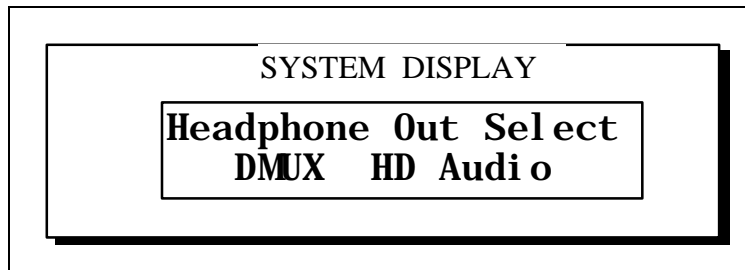

4.1.13 BER Test Loopback MENU

This menu enables and disables Bit Error Rate Test Loopback. The options selected by the FIELD switch are ENABLED and DISABLED.

For normal operation of the INT-9651 multiplexer and demultiplexer this MUST BE DISABLED.

When enabled the demultiplexer PCM input is directly routed to the multiplexer and output. This loopback allows an external BER test set to transmit a known data pattern, and compare the received data pattern with that transmitted. These should be identical. Any differences are counted by the BER test set as errors. In the INT-9651 the connection of demultiplexer received data into the multiplexer for output is between the 32 x 32 crosspoint switching circuits of the demultiplexer and multiplexer. Thus the INT-9651 components tested are the demultiplexer LIU, clock recovery PLL circuit, framer, and crosspoint switch circuit, the multiplexer crosspoint switch circuit, clock synchronization PLL circuit, framer and LIU. Items not in the BER test are the parallel access circuits and the Codecs.

For E1 BER testing the Telecommunications Techniques Corp. TTC InterCEPTOR 1403S BER test set is recommended. For T1 BER testing the TTC T-BERD 211 is recommended.

For BER testing of the INT-9651 perform the following procedure:

- Attach XMIT TWINAX cable from BER test set to demultiplexer T1/E1 input.
- Attach RCV TWINAX cable to BER test set from multiplexer T1/E1 output.
- Using the MUX Operating Mode and DMUX Operating Mode MENU's, set the INT-9651 framing, and zero code suppression to that of the BER test set.
- Using the DMUX Input Selection MENU select External Connector.
- Using the MUX Clock Selection MENU select DMUX Recovered.
- Using the BER Test Loopback MENU select Enabled.
- Verify BER test set has frame lock, data pattern lock and no errors.

4.2 Remote Control

Remote control is accomplished via the RS-232 or IEEE-488 interfaces. Commands to and responses from the INT-9651 are in the form of either upper or lower case ASCII characters. Commands follow the format below and are terminated with a carriage return:

```
cccc xxx yyy zzz ...etc...<CR>
```

cccc is the command verb
xxx yyy zzz ...etc... are command parameters

The command verb and each parameter consists of one or more printable ASCII characters (e.g. ASCII code > 20 hex). The command verb and each parameter are separated by one or more non-printable characters such as a space (ASCII code 20 hex), or by a comma or equals character. Any separation characters before the command verb or after the last parameter are ignored. BS (backspace) or DEL (delete) erases the character immediately preceding it, and are useful in correcting keyboard entry errors. After its initial power on message the unit maintains the "speak only when spoken to discipline", responding to commands and status queries that are received and prompting the user with a > character for the next command. Any command line beginning with a slash character is treated as a comment and ignored.

The following response is sent when an invalid command has been received:

```
<CR>ERROR: INVALID COMMAND  
<CR>><SP> Carr Rtn, >, Space
```

The following response is sent when an invalid parameter has been received:

```
<CR>ERROR: INVALID PARAMETER  
<CR>><SP> Carr Rtn, >, Space
```

The following response is sent when a valid command has been completed:

```
<CR>><SP> Carr Rtn, >, Space
```

4.2.1 On-Line HELP Facility

The command verb HELP results in the following:

>HELP

INIT - Restart System
INFO - Report Version
STATE - Report State
RALRM - Report Alarms
SMOPM - Set MUX Operating Mode
SDOPM - Set DMUX Operating Mode
SDX - Set DMUX Crosspoint Switch
SMX - Set MUX Crosspoint Switch
SDHST - Set DMUX Headphone Scan Table
SMHST - Set MUX Headphone Scan Table
SMCLK - Set MUX Reference Clock
SDCLK - Set DMUX Clock Output
SHDS - Set Headphone Audio Source
SDCS - Set DMUX CEPT Input Source
SDFLT - Set All to Defaults
DLOGO - Display Logo
DALRM - Display Alarms
HELP - Help

4.2.2 Remote Commands

The remote commands are listed below. Refer to the front panel operation commands above for a more detailed explanation of the effects of the command selections.

INIT -- Resets and restarts the system. It is the same as initial power on or the reset switch.

INFO -- Reports the manufacturer, model, date and version of firmware.

STATE -- Reports the current configuration of the unit using the format of input commands.

RALRM -- Reports the status of the alarms for the DEMUX PCM input signal. An ERR represents an ON alarm condition and a OK alarm is OFF.

When the demultiplexer is in E1 mode two alarm conditions are reported:

FSYNC = Loss of E1 Frame Synchronization
AIS = Alarm Indication Signal (PCM input signal is All 1's)

When the demultiplexer is in T1 mode two alarm conditions are reported:

FSYNC = Loss of T1 Frame Synchronization
YALR = Yellow Alarm Indication Signal

SMOPM -- Set the multiplexer operating mode.

The command format is: SMOPM XXXX YYYY ZZZZ
Example: SMOPM T1ESF B8ZS ULAW

XXXX is the framing mode. Valid options are: E1, T1ESF, T1D and T1SLC

YYYY is the zero suppression code (ZCS). When the framing mode is E1, valid options are HDB3 and NONE. When the framing mode is any of the T1 variants, valid options are B8ZS, B7HI and NONE.

ZZZZ is the sample companding code. When the framing mode is E1, ALAW is implied (and need not be typed in). When the framing mode is T1, valid options are ULAW and 2CPL (twos complement).

SDOPM -- Set the demultiplexer operating mode.

The command format is: SDOPM XXXX YYYY ZZZZ
Example: SDOPM T1ESF B8ZS ULAW

XXXX is the framing mode. Valid options are: E1, T1ESF, T1D and T1SLC

YYYY is the zero suppression code (ZCS). When the framing mode is E1, valid options are HDB3 and NONE. When the framing mode is any of the T1 variants, valid options are B8ZS, B7HI and NONE.

ZZZZ is the sample companding code. When the framing mode is E1, ALAW is implied (and need not be typed in). When the framing mode is T1, valid options are ULAW and 2CPL (twos complement)

SDX -- Set the DEMUX Crosspoint Switch to connect an output to an input.

The command format is: **SDX XXX YYY.**

Example: **SDX HD SCAN**

XXX is the output. This can be the numbers 1-15 and 17-31 for the rear panel VF output BNC's, HD for headphone audio, XTR for EXTRACT, or ALL.

YYY is the input. This can be the number 1-31 for E1 input timeslots or 1-24 for T1 input timeslots, DFLT for default, or SCAN (for HD output only).

SMX -- Set the MUX Crosspoint Switch to connect an output to an input.

The command format is: **SMX XXX YYY.**

Example: **SMX ALL 18**

XXX is the output. This can be the numbers 1-31 for the E1 output time slots or 1-24 for T1 output timeslots, HD for headphone audio, or ALL.

YYY is the input. This can be the numbers 1-15 and 17-31 for rear panel VF input BNC's, INS for INSERT, DFLT for default or SCAN (for HD output only).

SDHST -- Set DMUX Headphone Scan Table Delay.

The command format is: **SDHST XX YY.**

Example: **SDHST 2 4**

XX is the input. This can be the numbers 1-31 for the E1 input time slots or 1-24 for T1 input time slots or ALL.

YY is the dwell time. This can be OFF, DFLT for default, or 1 - 99 seconds.

SMHST -- Set MUX Headphone Scan Table Delay.

The command format is: **SMHST XX YY.**

Example: **SMHST 2 4**

XX is the input. This can be the numbers 1-15 or 17-31 for the VF audio input rear panel BNC's, INS for INSERT, or ALL.

YY is the dwell time. This can be OFF, DFLT for default, or 1 - 99 seconds.

SMCLK -- Set MUX Reference Clock Source.

The command format is: SMCLK XXXX YYYY ZZZZ
Example: SMCLK INT 8KHZ OUT

Valid commands are:
SMCLK INT 8KHZ OUT
SMCLK INT BITCLK OUT
SMCLK EXT 8KHZ IN
SMCLK EXT BITCLK IN
SMCLK DMUX

SDCLK -- Set DEMUX Clock Output.

The command format is: SDCLK XXXX
Example: SDCLK 8KHZ

Valid commands are:
SDCLK 8KHZ
SDCLK BITCLK

SHDS -- Set Headphone and Speaker Audio Output Source.

The command format is: SHDS XXXX
Example: SHDS MXHD

Valid commands are:
SHDS MXHD mux headphone output
SHDS DMXHD dmux headphone output
SHDS MXINS INSERT
SHDS DMXXTR EXTRACT
SHDS OFF

SDCS -- Set DMUX PCM Input Source.

The command format is: SDCS XXXXXX
Example: SDCS EXTERN

Valid commands are:
SDCS EXTERN
SDCS MUXOUT

SDFLT -- Set unit to all defaults for E1 or T1 operating modes.

The command format is: SDFLT XX
Example: SDFLT T1

Valid commands are:

SDFLT E1
SDFLT T1

When E1 is selected the following defaults are set:

E1 CEPT, HDB3, ALAW

DMUX Output Select

HEADPHONE connected to E1 IN timeslot 1
VF Audio BNC OUT 1-15, 17-31 to E1 IN timeslot 1-15, 17-31
EXTRACT connected to E1 IN 16

MUX Output Select

HEADPHONE connected to VF Audio BNC 1 IN
E1 OUT timeslot 1-15, 17-31 to VF Audio BNC IN 1-15, 17-31
E1 OUT timeslot 16 to INSERT

DMUX Headphone Scan Table

E1 IN timeslots 1-31, 3 seconds each.

MUX Headphone Scan Table

VF Audio BNC IN 1-15, 17-31, 3 seconds each.
INSERT, 3 seconds.

MUX Clock Source INTERNAL, 8KHz OUT

DMUX Clock Output 8 KHz

Headphone Source OFF

DMUX CEPT Source External Connector

When T1 is selected the following defaults are set:

T1ESF, B8ZS, ULAW

DMUX Output Select

HEADPHONE connected to T1 IN timeslot 1
VF Audio BNC OUT 1-15, 17-24 to T1 IN timeslot 1-15, 17-24
VF Audio BNC OUT 25-31 to T1 IN timeslot 1
EXTRACT connected to T1 IN 16

MUX Output Select

HEADPHONE connected to VF Audio BNC 1 IN
T1 OUT timeslot 1-15, 17-24 to VF Audio BNC IN 1-15, 17-24
T1 OUT timeslot 16 to INSERT

DMUX Headphone Scan Table

T1 IN timeslots 1-24, 3 seconds each.

MUX Headphone Scan Table

VF Audio BNC IN 1-15, 17-24, 3 seconds each.
INSERT, 3 seconds.

MUX Clock Source INTERNAL, 8KHz OUT

DMUX Clock Output 8 KHz

Headphone Source OFF

DMUX CEPT Source External Connector

DLOGO -- Display logo menu on front panel.

The command format is: DLOGO XXXXX

Example: DLOGO DESC

Valid commands are:

DLOGO DESC

DLOGO MODEL

DLOGO VER

DALRM -- Display alarms menu on front panel.

The command format is: DALRM

Example: DALRM

5.0 *Specifications*

E1 CEPT IN / CEPT OUT	ITU G.703, G.712 Twinax Bayonet, Balanced, 120 Ohms Zero Code Suppress (User Selectable), HDB3 or None A-Law Companding
T1 IN / OUT	ANSI T1.403, T1.408 Framing options are Super Frame (SF or D4), Extended Super Frame (ESF or D5), or SLC-96 (Non-Signaling) Twinax Bayonet, Balanced, 100 Ohms Zero Code Suppress (User Selectable), B8ZS, Bit 7 High or None U-Law or Twos Complement Linear Code
Audio In / Out	+3dBm0 maximum, 600 Ohms, Unbalanced, BNC
Clock In	TTL Levels, 50 % +/- 5% duty cycle 75 Ohms, BNC
Clock Out	TTL Levels, 50% +/- 5% duty cycle BNC
Headphone	Front panel mini-jack with volume adjust
Speaker	Internal, 7 Watt amplifier, Off/On & volume adjust
Remote Control	RS-232C 9 pin D (RS-232), 19,200 bps IEEE-488 Optional
Front Panel	VFD display, 2x20 lines Switches, MENU, FIELD, VALUE ENTER, RESET
A/C Power Input	115 VAC, 47 - 63 Hz, 20 Watts
Physical	3.5" H, 24" D, 19" Rack Mount, 17 lbs.